

Fixed Speed Wind Power Plant for Grid Code Compliance in India

M. G. Sugirtha

Research Scholar,
Anna University, Chennai, Tamilnadu, India
Email: mgsugirtha@gmail.com

P. Latha

Associate Professor and Head,
Government College of Engineering,
Tirunelveli, Tamilnadu, India

Abstract – Fixed speed wind turbine consisting of induction generator is the simplest wind energy conversion system because of its robustness, reliability and simplicity. Due to the development of power electronics different configurations of variable speed concept in wind energy schemes are available. But still in India, grid behavior is dominated by fixed speed wind farms consisting of induction generators. In olden days wind power penetration into grid was very low. A grid connection requirement in order to keep acceptable and reliable operation of the power system was not needed because of this low level of wind penetration. There are an important amount of fixed speed generators still in use that have to be upgraded to the new grid code requirements. Wind turbines with induction generator need reactive power support. A simulation based analysis is carried out to investigate the suitability of application of a STATCOM to achieve Indian grid code compliance of 60MW wind farm with fixed speed induction generator. The rating requirement of the capacitor bank for the wind generation application has been investigated. The compatibility of wind farms having fixed speed generators with Indian grid code requirement is evaluated using Matlab/Simulink.

Keywords – Reactive Power, Grid Code, Fixed Speed Wind Farm, Power Quality, STATCOM, Induction Generator.

List of symbols

R_s, R_r, R = p.u. per phase stator, rotor and load resistance, respectively.

X_{ls}, X_{lr}, X, X_m = p.u per phase stator leakage, rotor leakage, load and magnetising reactances respectively.

X_{smax} = p.u maximum saturated magnetising reactance.

C = per phase terminal-excitation capacitance.

X_c = p.u per phase capacitive reactance of the terminal excitation capacitor.

f, v = p.u frequency and speed respectively.

N = base speed in rev/min.

Z_b = per phase base impedance.

F = base frequency.

V_g, V_0 = per phase airgap and output voltages respectively

I. INTRODUCTION

In recent years, there has been a worldwide tremendous development in the utilization of wind farms. Wind power industry is developing speedily, more and more new wind farms are being connected into the prevailing power system networks. In the next years, it is expected to have more significant growth in wind energy. Although there is great development in the technology of electrical generation from wind energy, only one way of generating electricity from wind energy is technically feasible. It is

the method of using wind turbines that convert the energy contained in flowing air into electricity. [1]. Wind Resource Assessment as declared by Government of India has an indicative potential of 103 GW at 80m above ground level. The total installed capacity of wind power by the end of May 2013 is 19.3GW which is less than 20% of indicated capacity. [2]. In general, Grid code regulations are defined by system operators to outline the rights and responsibilities of all the generators and loads that are connected to the transmission/distribution system. In the past, wind power penetration level was extremely small compared to the conventional generation systems. So that grid codes did not include any regulations for Wind Power Plants (WPPs). However, the situation has completely changed during the last decade. In many countries the number and capacity of WPPs integrated into their electric networks have been increased. The shift from conventional energy resources into the renewable energy resources has raised serious concerns regarding the negative impacts of large WPPs. Since wind is intermittent in nature WPPs are being considered as intermittent generation units, decreasing the stability of existing power networks. To safeguard the network against these threats, system operators in many countries have enforced strict technical requirements on large WPPs. Modern grid codes require WPPs to not only withstand various grid disturbances, but also contribute to the network stability support and ancillary service provision, as do conventional generation units [3]. Reference [4] presents a comprehensive study on the latest grid code regulations enforced by transmission system operators on large wind power plants (WPPs). In India several states have high penetration of wind power and specific grid connection requirements (GCR) for wind power are yet to be established. Reference [5] proposes GCR for wind power integration in India and discusses several technical and operational issues arising due to high penetration of wind power generation in Indian power systems.

Power quality has been affected by injection of the wind power into an electric grid. The performance of the wind turbine and thereby power quality should be determined on the basis of measurements and the norms followed according to the guideline specified in International Electro-technical Commission standard, IEC-61400. The influence of the wind turbine in the grid system concerning the power quality measurements are the active power, reactive power, variation of voltage, flicker, harmonics, and electrical behavior of switching operation and these are measured according to national/international

guidelines. Reference [6] demonstrates the power quality problem due to installation of wind turbine with the grid. In this scheme STATicCOMPensator (STATCOM) is connected at a point of common coupling with a battery energy storage system (BESS) to mitigate the power quality issues.

Reference [7] denotes the final report of a joint Danish and Indian project “Power Quality and Integration of Wind Farms in Weak Grids”. The power quality issues have been studied and analyzed with the Indian conditions as a case. The critical power quality aspects in India have been identified. Measurements on selected wind farms and wind turbines have quantified the power quality, and analyses of power quality issues, especially reactive power compensation, have been performed. Based on measurements and analyses, preliminary recommendations for grid integration of wind turbines in weak grids have been formulated. Since there are not too many experimental works assessing the power quality in wind farms according to the IEC 61400-21 standard, the work done by J.J. Gutierrez et al, in [8] can be useful to enlarge the knowledge about the influence of the wind turbines on the power quality.

In fixed speed induction generator, high starting current is required for its operation and hence demand for reactive power is high. It draws reactive power from the grid and so the consumption of electricity and cost is also high. This paper presents a solution for reactive power management of fixed speed wind power plant by finding the minimum value of capacitance required and thereby applying that value for capacitor bank thereby providing rating for STATCOM in the Simulink diagram for reactive power compensation by considering the Indian wind grid code. The Indian grid code lays down certain rules and regulations to be followed by various agencies to plan and operate the power system in a reliable manner. A new simple and direct method is developed to find the equations for capacitance calculation, and using those equations, a MATLAB program is written and capacitive reactance is calculated under various load conditions. Simulink diagram is implemented and by providing appropriate values, the reactive power is compensated as per Indian wind grid code.

II. FIXED SPEED WIND FARM

Fixed speed wind turbines utilize squirrel cage induction generator directly connected to the grid to produce the electricity as shown in Figure1. These induction generators which are usually connected at weak end of a grid or at distribution networks draw large amount of reactive currents during disturbances such as faults. Consequently under these conditions the terminal voltage and the electrical output power are significantly reduced, whereas the mechanical torque may be still applied to the wind turbine and the rotor speed increases.[1]

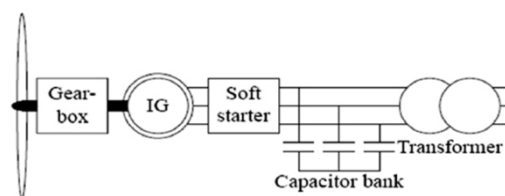

Fig.1. Fixed speed wind turbine with induction generator

At no load (idling), the reactive power consumption is about 35-40% of the rated active power, and increases to around 60% at rated power. Reactive power is one of the major causes of voltage instability in the network due to the associated voltage drops in the transmission lines, reactive current also contributes to system losses.[9]

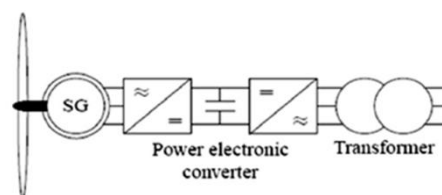

Fig.2. Variable-speed direct-driven (gearless) wind turbine with a synchronous generator

The disadvantage of the variable-speed turbine is a more complex electrical system, because a power-electronic converter is needed to make the variable-speed operation possible. A straightforward way to obtain variable speed is to connect a converter directly between the stator circuit of the generator and the grid as shown in figure 2. This converter has to be designed for the rated power of the turbine. Because of the needed power electronic converter, the price of variable-speed turbines tends to be higher than constant speed turbines.[10]

Variable speed generators can have maximum power capture capability. But variable speed generators are not the only ones installed in wind farms. Still there are an important number of fixed speed generators in use and that have to be upgraded to the new grid code requirements. Reference [11] presents a solution for wind farms with fixed-speed generators based on the use of STATCOM with braking resistor and additional series impedances, with an adequate control strategy. The focus is put on guaranteeing the grid code compliance when the wind farm faces an extensive series of grid disturbances.

III. INDIAN WIND GRID CODE

The Indian grid code lays down the rules and standards to be followed by various agencies to plan and operate the power system in a reliable manner [15]. The grid codes for wind, in general deal with the following issues.

A. Active power control

This is the ability of the wind turbine generators to regulate the active power output of the wind turbine according to system requirements. Active power control of wind turbine is to ensure a stable frequency in the system, to prevent overloading of transmission lines to avoid

inrush current during start up and shut down of wind turbines. During a fault, if the wind turbine were to stay on line, the active power output has to be reduced in a controlled manner to prevent tripping of generator.

B. Frequency requirements

System frequency is a major indicator of the power balance in the system. In India, the frequency varies from 48.5-51.5 Hz due to the power imbalance. Low penetration of wind turbines does not affect the system frequency. High penetration of wind turbines can have significant impact on the grid.

C. Voltage and reactive power issues

Wind turbines with induction generators need reactive power support. Capacitor banks are the preferred method of reactive power compensation in wind farms. If not properly compensated reactive power draw from the system can cause increased losses, overheating and de-rating of the lines. Thus, the behavior of different types of wind turbines can be standardized by means of the grid code.

D. Low voltage ride through capability

This refers to the ability of the wind turbine to remain connected to the grid without tripping from the grid for a specified period of time during a voltage drop at the point of connection. The period of fault ride through depends on the magnitude of voltage drop at the point of common coupling during the fault and the time taken by the grid system to recover to the normal state.

E. Wind farm protection

Wind farms are required to be equipped with under frequency and over frequency protection, differential protection and back up protection.

F. Data requirements

Monitoring of large wind farms to obtain up-to-date information on the real time status of the wind farm is essential. This will help in tracking dynamic changes that the wind farm will undergo. The system operator can change the set point according to the operating conditions.

G. Power quality issues like flicker, harmonics

Flicker is defined as the visual fluctuations in the light intensity as a result of voltage fluctuations and is caused by wind turbines, both during continuous operations and switching operations.

In case of large wind farms connected to the grid, wind turbines are required to remain connected to the grid within specified voltage and frequency limits. High short circuit current, under voltages, over voltages during and after fault can damage the wind turbine.

IV. PROBLEM FORMULATION

In the case of fixed speed wind turbines, reactive power is required for machine excitation. This reactive power is supplied by the capacitor banks installed at the terminal of the squirrel cage induction generator. Even though capacitors provide simplest solution for reactive power compensation, they cannot provide dynamic compensation for transient conditions. Flexible AC Transmission System

(FACTS) controllers such as Static Var Compensator (SVC) or Static Synchronous Compensator (STATCOM) can provide suitable compensation for fixed speed wind farm. The contribution of Static Synchronous Compensator STATCOM to support the fixed-speed wind farm interconnected electric grid during different fault locations and different fault duration times are investigated by Omar Nourelddeenetal in [12].The analysis of the reactive power management of a wind farm consisting of fixed speed wind turbines was carried out by H.M. EL-Helwetal. The rating calculation of the compensator for a fixed speed wind farm was evaluated, and the effect of the network strength on the compensator rating was studied. Also the compatibility of fixed speed wind turbine with the new UK grid code requirements was evaluated by simulation using Matlab/Simulink.[13].

Normally the value of reactive power required by grid connected induction machine can be provided by STATCOM. But if the entire power is supplied by STATCOM only, then rating of the controller will be high and costly. Fixed capacitor banks should be used with STATCOM controller to reduce its rating. The maximum reactive power that can be provided by fixed capacitor bank is the no-load requirement of wind farm. STATCOM can supply remaining reactive power required under loaded conditions. The capacitance value required for reactive power compensation in grid connected induction machine can be calculated by mesh analysis method in [14].

Advanced knowledge of the minimum capacitor value required for self-excitation of an induction generator is of practical interest. To find this capacitor value two nonlinear equations have to be solved. Different numerical methods for solving those equations are presented. This requires a trial and error procedure. In this paper a new simple and direct method is developed to find the capacitance requirement under RL load. Exact values are derived for the minimum capacitance required for self-excitation and output frequencies. These calculated values can be used to predict theoretically the minimum value of the terminal capacitance required for self-excitation. For stable operation C must be chosen to be slightly greater than C_{min} . Per phase steady state equivalent circuit of grid connected Induction generator with RL load is shown in Figure 3.

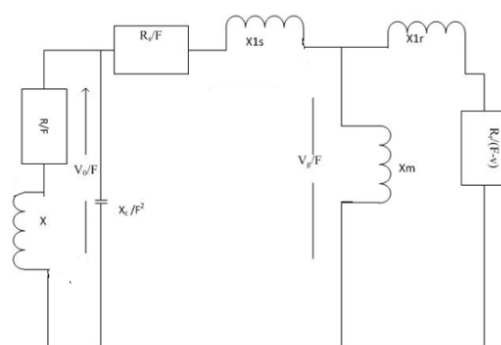

Fig.3. Per phase steady state equivalent circuit of grid connected Induction generator with RL load

Drawing the equivalent circuit with simple terms, for making the derivation simple, all the inductance and capacitance are replaced with simple resistances as shown in Figure 4. Finally all the values will be replaced with the original terms.

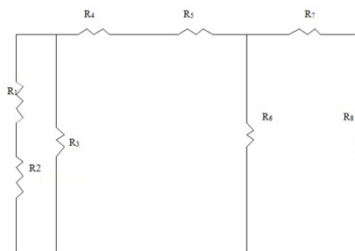

Fig.4. Per phase steady state equivalent circuit of grid connected Induction generator after replacing all capacitors and inductors by resistances.

Let $R_1 = R/F$, $R_2 = jX$, $R_3 = -j(X_c/F^2)$, $R_4 = R_s/F$, $R_5 = jX_{ls}$, $R_6 = jX_m$, $R_7 = jX_{lr}$, $R_8 = R_r/(F-v)$

The equivalent impedance of the circuit is given by,

$$Z = ((R_1+R_2) \parallel R_3) + (R_4+R_5) + (R_6 \parallel (R_7+R_8))$$

By using the parallel resistance method, solve the above equation

$$R_1 R_3 R_6 + R_1 R_3 R_7 + R_1 R_3 R_8 + R_2 R_3 R_6 + R_2 R_3 R_7 + R_2 R_3 R_8 + R_1 R_6 R_7 + R_2 R_6 R_7 + R_3 R_6 R_7 + R_1 R_6 R_8 + R_2 R_6 R_8 + R_3 R_6 R_8 + R_1 R_7 R_4 + R_1 R_8 R_4 + R_2 R_7 R_4 + R_2 R_8 R_4 + R_3 R_7 R_4 + R_3 R_8 R_4 + R_1 R_6 R_5 + R_1 R_7 R_5 + R_1 R_8 R_5 + R_2 R_6 R_5 + R_2 R_7 R_5 + R_2 R_8 R_5 + R_3 R_6 R_5 + R_3 R_7 R_5 + R_3 R_8 R_5 = 0$$

Now substitute the values for $R_1, R_2, R_3, R_4, R_5, R_6, R_7, R_8$ in the above equation and Grouping it in terms of F^3, F^2, F

$$F^3(X_m X_{lr} R + XX_m R_r + XX_m R_s + XX_{lr} R_s + X_m X_{ls} R + X_{lr} X_{ls} R + XX_{ls} R_r) + F^2(X_m X_{lr} R v + XX_m R_s v + XX_{lr} R_s v + X_m X_{ls} R v + X_{lr} X_{ls} R v) + F(X_c(X_m R + X_{lr} R + X R_r + X_m R_r + X_{ls} R_r + X_m R_s + X_{lr} R_s) + R R_r R_s)$$

$$-X_c(X_m R v + X_{lr} R v + X_m R_s v + X_{lr} R_s v) = 0$$

$$-A_1 F^3 + A_2 F^2 + (A_3 X_c + A_4) F - A_5 X_c = 0 \quad (1)$$

Where

$$A_1 = X_m X_{lr} R + XX_m R_r + XX_m R_s + XX_{lr} R_s + X_m X_{ls} R + X_{lr} X_{ls} R + XX_{ls} R_r$$

$$A_2 = X_m X_{lr} R v + XX_m R_s v + XX_{lr} R_s v + X_m X_{ls} R v + X_{lr} X_{ls} R v$$

$$A_3 = X_m R + X_{lr} R + X R_r + X_m R_r + X_{ls} R_r + X_m R_s + X_{lr} R_s$$

$$A_4 = R R_r R_s$$

$$A_5 = X_m R v + X_{lr} R v + X_m R_s v + X_{lr} R_s v$$

Similarly Take the imaginary parts alone and Neglecting the term j in all the terms, and grouping it in terms of F^4, F^3, F^2, F

$$-F^4(XX_m X_{lr} + XX_m X_{ls} + XX_{lr} X_{ls}) + F^3(XX_m X_{lr} v + XX_m X_{ls} v + XX_{lr} X_{ls} v) +$$

$$F^2(X_c(XX_m + XX_{lr} + X_m X_{lr} + X_m X_{ls} + X_{lr} X_{ls}) + X_m R R_r + X_{lr} R R_s + X R R_r + X_m R R_s + X_{ls} R R_r)$$

$$-F(X_c(XX_m v + XX_{lr} v + X_m X_{lr} v + X_m X_{ls} v + X_{lr} X_{ls} v) + X_m R R_s v + X_{lr} R R_s v) - X_c(R R_r + R_r R_s)$$

This equation is again equated to zero. Thus,

$$-B_1 F^4 + B_2 F^3 + (B_3 X_c + B_4) F^2 - (B_5 X_c + B_6) F - X_c B_7 = 0 \quad (2)$$

Where,

$$B_1 = XX_m X_{lr} + XX_m X_{ls} + XX_{lr} X_{ls}$$

$$B_2 = XX_m X_{lr} v + XX_m X_{ls} v + XX_{lr} X_{ls} v$$

$$B_3 = XX_m + XX_{lr} + X_m X_{lr} + X_m X_{ls} + X_{lr} X_{ls}$$

$$B_4 = X_m R R_r + X_{lr} R R_s + X R_r R_s + X_m R R_s + X_{ls} R R_r$$

$$B_5 = XX_m v + XX_{lr} v + X_m X_{lr} v + X_m X_{ls} v + X_{lr} X_{ls} v$$

$$B_6 = X_m R R_s v + X_{lr} R R_s v$$

$$B_7 = R R_r + R_r R_s$$

From equation (1)

$$-A_1 F^3 + A_2 F^2 + (A_3 X_c + A_4) F - A_5 X_c = 0$$

$$X_c = \frac{A_1 F^3 - A_2 F^2 - A_4 F}{(A_3 F - A_5)} \quad (3)$$

From eqn. 2

$$-B_1 F^4 + B_2 F^3 + (B_3 X_c + B_4) F^2 - (B_5 X_c + B_6) F - X_c B_7 = 0$$

$$X_c = \frac{B_1 F^4 - B_2 F^3 - B_4 F^2 + B_6 F}{B_3 F^2 - B_5 F - B_7} \quad (4)$$

Since eqn. 3 and eqn. 4 denote X_c , we can equate both.

And again group them in terms of F^4, F^3, F^2, F ,

$$F^4(A_1 B_3 - B_1 A_3) - F^3(A_1 B_5 + A_2 B_3 - B_2 A_3 - B_1 A_5) + F^2(A_2 B_5 - A_1 B_7 - A_4 B_3 + B_4 A_3 - B_2 A_5) - F(-A_2 B_7 - A_4 B_5 + B_6 A_3 + B_4 A_5) + (A_4 B_7 + B_6 A_5) = 0$$

Rewriting it as

$$\alpha_4 F^4 - \alpha_3 F^3 + \alpha_2 F^2 - \alpha_1 F + \alpha_0 = 0 \quad (5)$$

Special cases:

No load capacitance requirement

$$C_{min} = \frac{[2\pi f_b Z_b (X_{lr} + X_{smax}) * ((R_s/R_r) F_{max} (F_{max} v) + F_{max}^2))]}{[2\pi f_b Z_b (X // (X_{lr} + X_{smax})) * (v + (v^2 (4R_s R_r / X_{smax}^2))^{1/2})]^{-1}}$$

Inductive load capacitance requirement

$$C_{min} = \frac{4[2\pi f_b Z_b (X // (X_{lr} + X_{smax})) * (v + (v^2 (4R_s R_r / X_{smax}^2))^{1/2})]^{-1}}{[2\pi f_b Z_b K_1 F_{max} ((F^2_{max} - v F_{max} - K_2) / (F_{max} - v K_3))]^{-1}}$$

Resistive load capacitance requirement

$$C_{min} = \frac{[2\pi f_b Z_b K_1 F_{max} ((F^2_{max} - v F_{max} - K_2) / (F_{max} - v K_3))]^{-1}}{[2\pi f_b Z_b K_1 F_{max} ((F^2_{max} - v F_{max} - K_2) / (F_{max} - v K_3))]^{-1}}$$

Output is:

Minimum capacitance requirement at no load is 17.98 μF

Minimum capacitance requirement at Inductive load is 97.24 μF

Minimum capacitance requirement at Resistive load is 46.42 μF

V. SYSTEM DESCRIPTION

The Wind Farm consisting of 60 MW aggregated Wind Turbine is connected to a 0.69-KV distribution system exports power to a 120-KV grid through feeder as shown in Figure5. Wind turbines use squirrel cage induction generator. The voltage rating of the Induction generator is 0.69 KV and the frequency is 50 Hz. The stator winding is connected directly to the 50Hz grid and the rotor is driven by a variable-pitch wind turbine. The pitch angle is controlled in order to limit the generator output power at its nominal value for winds exceeding the nominal speed

(9m/s). In order to generate power the IG speed must be slightly above the synchronous speed. Speed varies approximately between 1 pu at no load and 1.005 pu at full load. The wind turbine has a protection system monitoring voltage, current and machine speed. The protection system contains the trip signals to be given to the wind turbine.

Reactive power absorbed by the IG is partly compensated by capacitor banks connected at each wind turbine low voltage bus. The rest of the reactive power required to maintain the 11 kv voltage is provided by 3-Mvar STATCOM with a 3% droop setting and it is given in Figure6. The nominal wind speed yielding the nominal mechanical power is 9 m/s. The wind turbine model and STATCOM model are phasor models that allows transient stability type studies with long simulation times. In this simulation, the system is observed during 1 minute.

Then a conventional Capacitor is connected in parallel to the bus to inject the reactive power by minimal amount. A three phase Transformer winding is connected to the Three phase V-I Measurement block. This three phase transformer winding is a step up transformer. The Primary winding voltage of this transformer is 0.69 KV. The secondary winding voltage of this transformer is 11 KV. This section is again connected to a three phase V-I measurement block which acts as a bus. Then the transmission line for a very less length is represented by the three phase pi-section line.

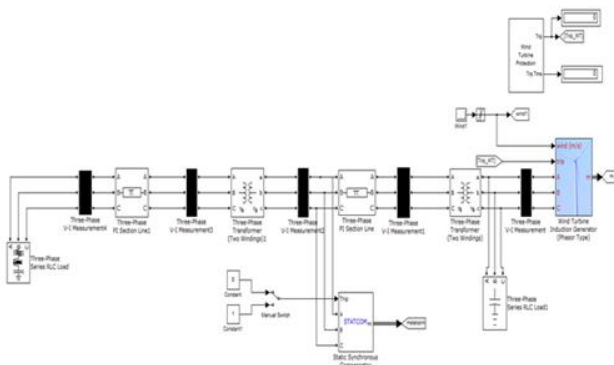

Fig.5. Simulink Diagram

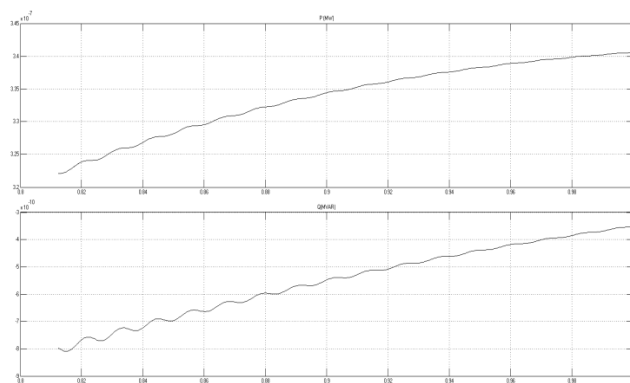

Fig.6. Real and reactive power of STATCOM

Connected in parallel with the three phase pi-section line is the STATCOM which is used to compensate the reactive power in the system. The Rating of the

STATCOM is chosen so as to comply with the Indian Grid code. The STATCOM itself is provided with a trip circuit. The trip circuit is connected to the STATCOM using a manual switch, whose ON/OFF position can be changed manually. A '0' position means the trip is inactive and '1' position means the trip is active.

VI. CONCLUSION

The minimum value of capacitance required for self excitation is calculated using Matlab program. Reactive power required by a grid connected induction machine can be calculated in a similar manner like capacitance of self excited isolated induction generator. Hence in this work the value of reactive power is derived using mathematical equations and the value is simulated using the Matlab coding. The capacitance value is applied to the Simulink diagram along with STATCOM and so that the simulation is done using Matlab Simulink. The output thus obtained is a compensated reactive power .The power factor is also within the limit as given by the Indian wind grid code. Thus the Reactive power compensation of wind power plant is done using STATCOM in accordance with the Indian wind grid code.

REFERENCES

- [1] Patel MR. Wind and solar power systems. Kings Point, New York: U.S. Merchant Marine Academy; 1999.
- [2] www.cwet.tn.nic.in
- [3] Anaya-Lara O, Jenkins N, Ekanayake J, Cartwright P, Hughes M. Wind energy generation modeling and control. Wiley; 2009.
- [4] Mansour Mohsenia, Syed M. Islamb. Review of international grid codes for wind power integration: Diversity, technology and a case for global standard. Renewable and Sustainable Energy Reviews 16 (2012) 3876– 3890.
- [5] Bharat Singha, S.N. Singh. Development of grid connection requirements for wind power generators in India. Renewable and Sustainable Energy Reviews 15 (2011) 1669–1674.
- [6] Sharad W. Mohod, and Mohan V. Aware. A STATCOM-Control Scheme for Grid Connected Wind Energy System for Power Quality Improvement. IEEE SYSTEMS JOURNAL, VOL. 4, NO. 3, SEPTEMBER 2010.
- [7] PoulSørensen and Peter Hauge Madsen, Risø, Denmark ,Anders Vikkelsø and K. Kølbaek Jensen, DEFU, Denmark ,K.A. Fathima, A.K. Unnikrishnan and Z.V.Lakaparampil, ER&DCI(T), India Risø. Power Quality and Integration of Wind Farms in Weak Grids in India. Risø National Laboratory, Roskilde, April 2000.
- [8] J.J. Gutierrez, J. Ruiz, P. Saiz, I. Azcarate, L.A. Leturiondo and A. Lazkano. Power Quality in Grid-Connected Wind Turbines. University of the Basque Country Spain. www.intechopen.com
- [9] Z. Chen, Issues of Connecting Wind Farms into Power Systems. 2005 IEEE/PES Transmission and Distribution Conference & Exhibition: Asia and Pacific Dalian, China.
- [10] G. Saccomando, J. Svensson, A. Sannino, Improving voltage disturbance rejection for variable-speed wind turbines, IEEE Trans. Energy Convers. 17 (June (3)) (2002) 422–428.
- [11] Dionisio Ramirez, Sergio Martinez, Francisco Blazquez, Carmelo Carrero. Use of STATCOM in wind farms with fixed-speed generators for grid code compliance. Renewable Energy 37 (2012) 202-212.
- [12] Omar Nourdeleen , Mahmoud Rihan , Barkat Hasanin. Stability improvement of fixed speed induction generator wind farm using STATCOM during different fault locations and durations. Ain Shams Engineering Journal (2011) 2, 1–10

- [13] H.M. EL-Helw, Sarath B. Tennakoon. Evaluation of the suitability of a fixed speed wind turbine for large scale wind farms considering the new UK grid code. Renewable Energy 33 (2008) 1–12.
- [14] Capacitance requirement for isolated self excited induction generator., A.K.AIJabri, Msc., MA., PhD., A.IAlolah, BSc., PhD, IEE Proceedings, Vol.137, Pt.B, No.3, May 1990.
- [15] Draft report on Indian Wind Grid Code, Centre for Wind Energy Technology (CWET), 2009.

AUTHOR'S PROFILE



M. G. Sugirtha

has received her B.E degree in Electrical and Electronics Engineering in 2001 from Manonmaniam Sundaranar University, Tirunelveli, India and M.E. degree in Power Electronics and Drives in 2005 from Anna University, Chennai, India. Currently she is an Assistant professor in the Department of Electrical Engineering. The Rajaas Engineering College, Tirunelveli, India and pursuing her Ph.D. degree from Anna University, Chennai, India. Her research focuses on Power Quality, Soft Computing Techniques, Wind Power, FACTS and Intelligent Controllers.



Dr. P. Latha

has received her master's degree in computer science and Engineering from Bharathiar university. She graduated from Madurai Kamaraj university in Electrical and Electronics Engineering. She received her Ph.D. degree from Anna University, Chennai in 2011. Currently she is an Associate professor and Head of Computer Science and Engineering Department in Government College of Engineering, Tirunelveli, India. She has published her research work in 4 International Journals, 6 National level journals and more than 40 national level conferences. Her field of specialization is image processing and soft computing Techniques.